

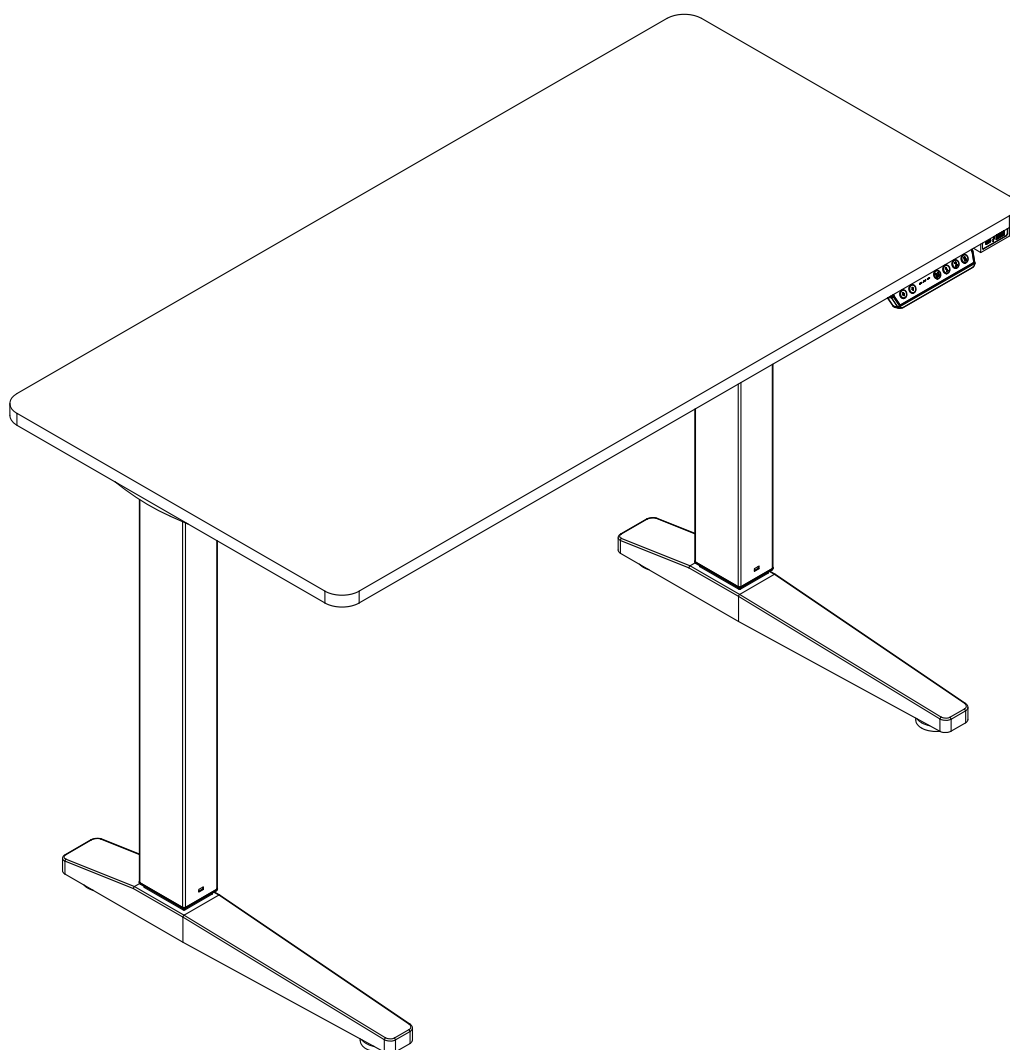

INSTRUCTION



 Part of the steps suggest
two people install

Main Components

Please check you have all the parts listed below

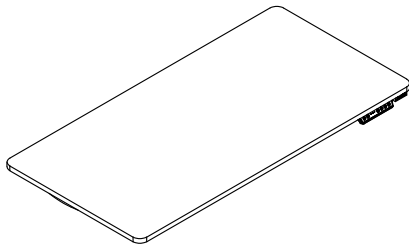

1 Table top Qty 1

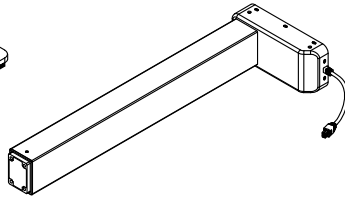

2 Leg Qty 2

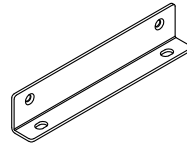

3 Bracket Qty 4

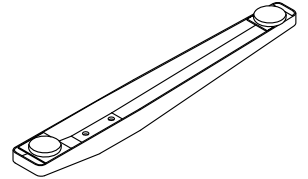

4 Foot Qty 2

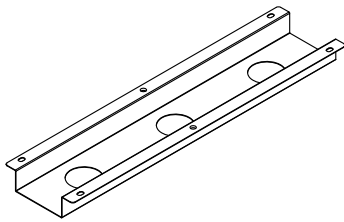

5 Tray Qty 1

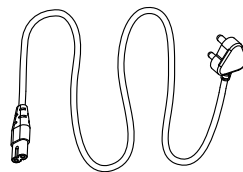

6 2m Power cord Qty 1

Fixings, Fittings And Tools

Please check all the fittings listed below

Note: The quantities below are the correct amount to complete the assembly. In some case more fittings may be supplied than be required.

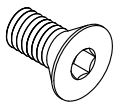

A M6*15mm Screw Qty 8

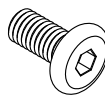

B M6*15mm Screw Qty 12

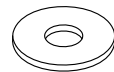

C Ø16.5mm Washer Qty 8

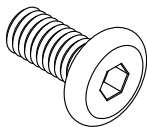

D M8*15mm Screw Qty 8

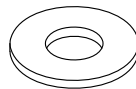

E Ø18.5mm Washer Qty 8

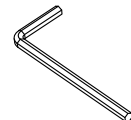

F M4 Allen key Qty 1

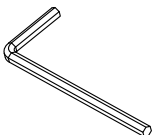

G M5 Allen key Qty 1

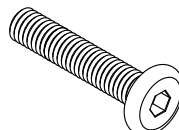

H M6*65mm Screw Qty 4

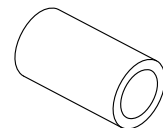

J 25mm Bolt Spacers Qty 8

Assembly Step

Step 1

Assemble brackets **3** to legs **2** using fixings **A**.

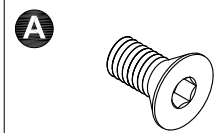

M6*15mm Screw Qty 8

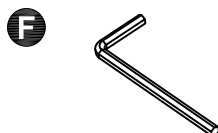

M4 Allen key Qty 1

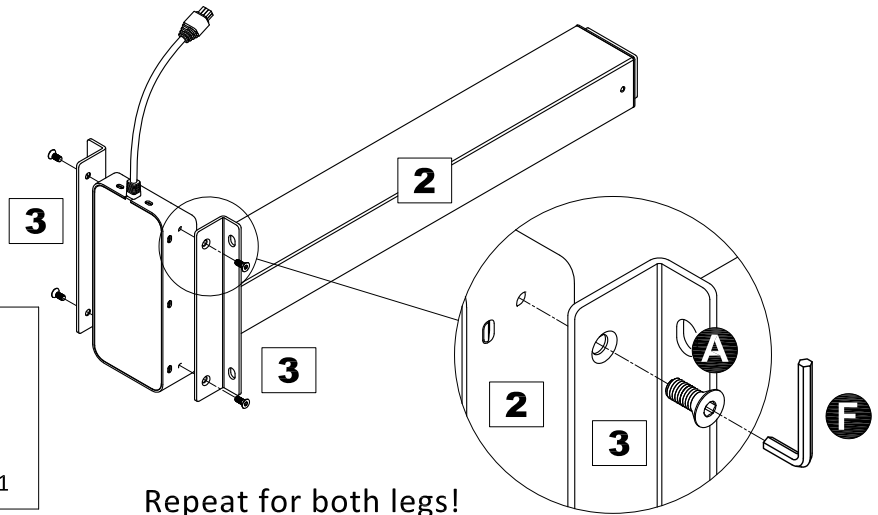

Repeat for both legs!

Step 2

With help, place desk top **1** upside down onto a clean flat surface.

Ensure the surface is suitably protected to prevent any damage to top **1**.

Assemble legs **2** to top **1** using fixings **B** and **C**.

Assemble feet **4** to legs **2** using fixings **D** and **E**.

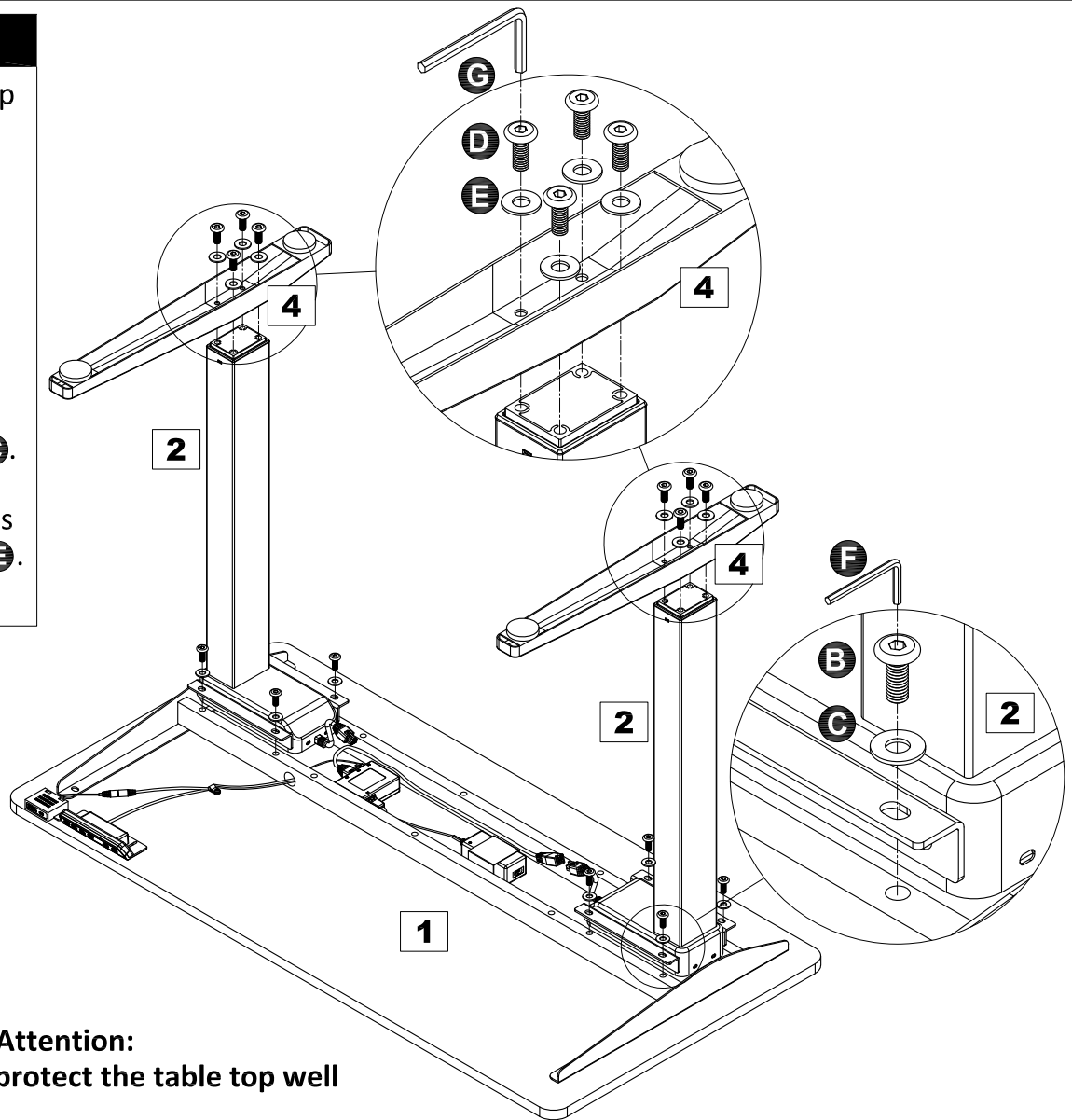

Attention:
protect the table top well

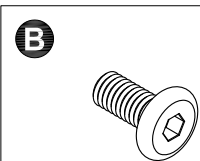

M6*15mm Screw Qty 8

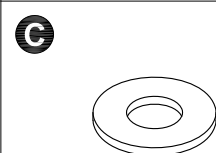

Ø16.5mm Washer Qty 8

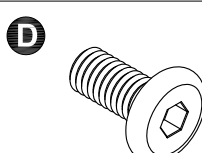

M8*15mm Screw Qty 8

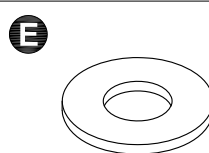

Ø18.5mm Washer Qty 8

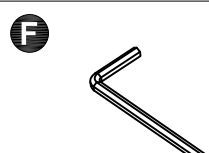

M4 Allen key Qty 1

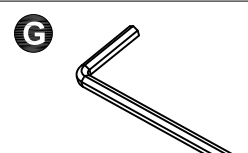

M5 Allen key Qty 1

Step 3

Connect all the lines correctly

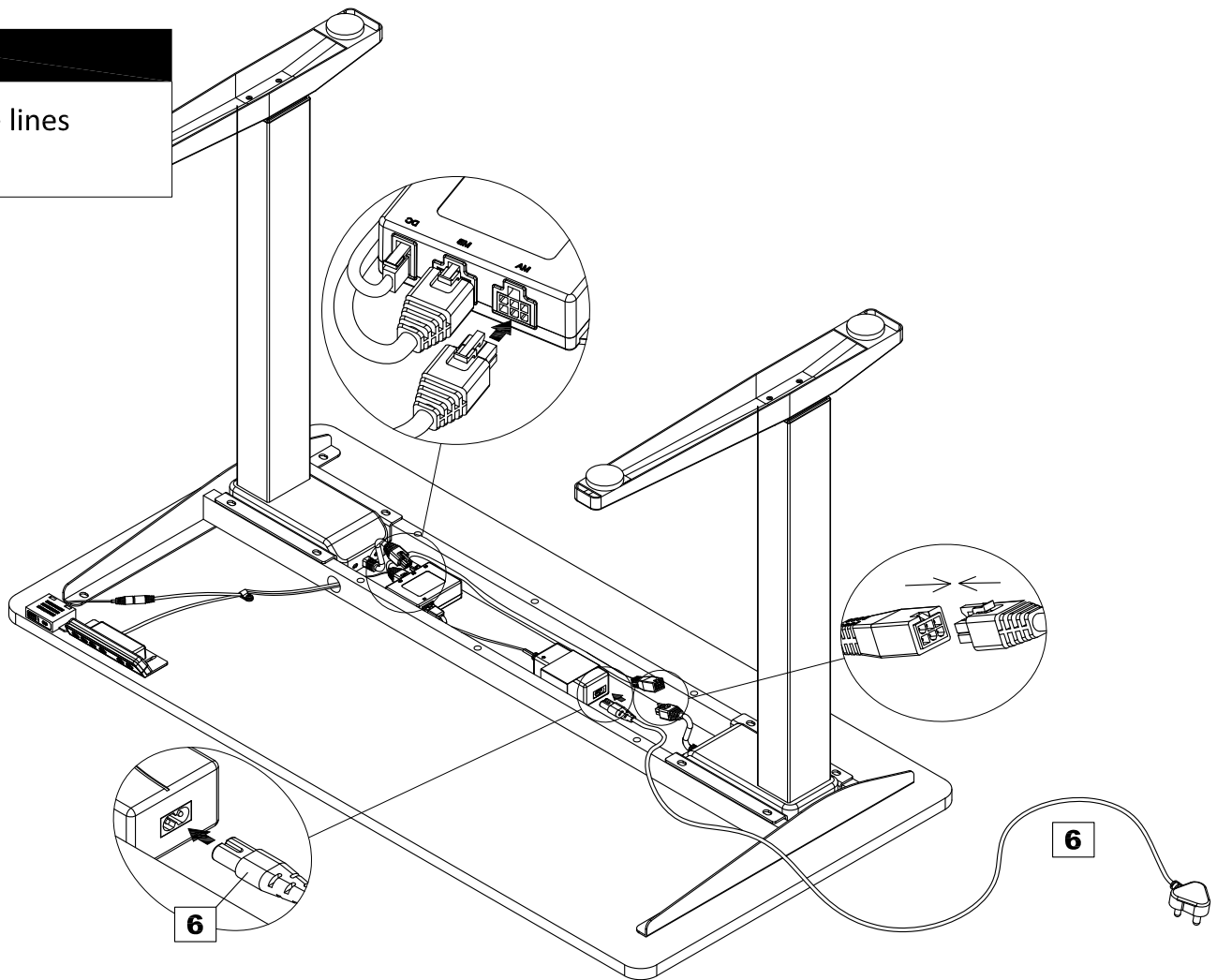

Step 4

Secure the tray **5** with screw **B** to the bottom of the table top

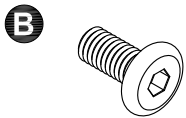
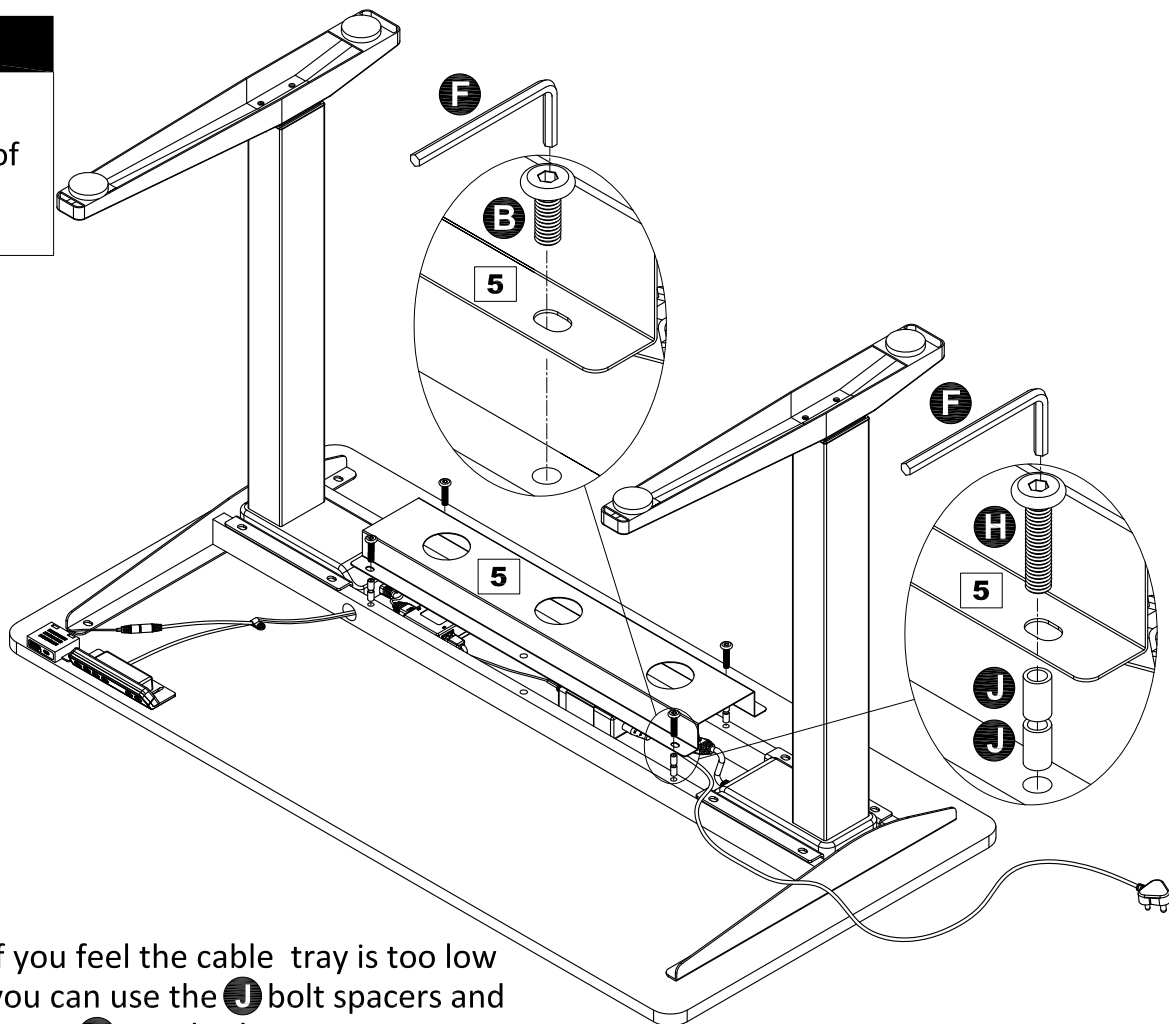

M6*15mm Screw Qty 4

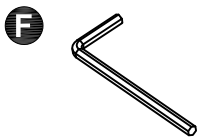

M4 Allen key Qty 1

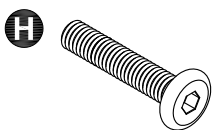

M6*65mm Screw Qty 4

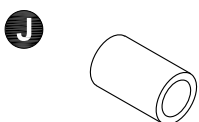

25mm Bolt Spacers Qty 8



If you feel the cable tray is too low you can use the **J** bolt spacers and screw **H** to raise it, you can use one or two of them.

Step 5

Tip:

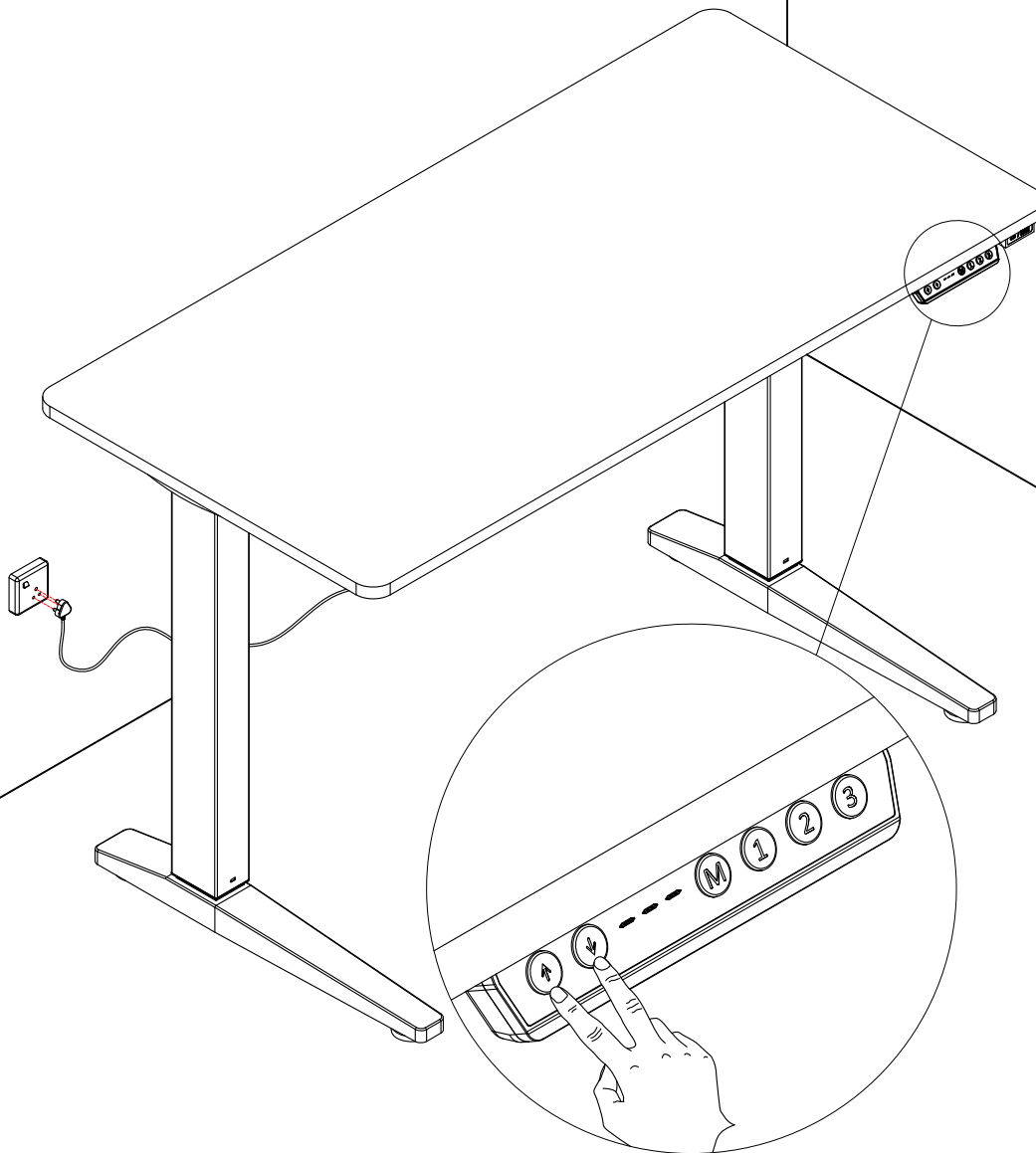
You need to reset the device for the first time, as shown in the following figure.



At the same time, press  and  keys for 8 seconds to display --- and then release, the desktop will automatically enter the initialization mode, the table will automatically run, wait to stop, it means that the initialization is successful.

Technical specification

VOLTAGE	AC100V-240V /50-60HZ
RATED INPUT VOLTAGE	100V-240V
FREQUENCY	50-60HZ
RATED CURRENT	1.3A
NOMINAL VOITAGE	29V
OUTPUT CURRENT	2A
MAXIMUM POWER	58W
APPLICABLE AMBIENT TEMPERATURE	-12°C to 45°C
USB & TYPE-C CHARGER	18W for USB charger 45W for TYPE-C charger

Features

- height adjustable
- USB model input

USB charger

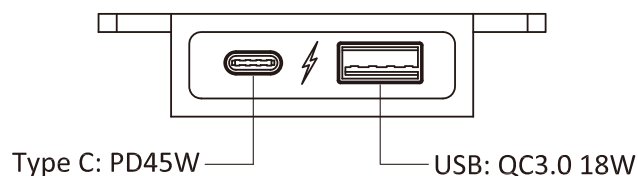

Please connect correctly with type C and the USB charger with desk.

Operations

Key introduction

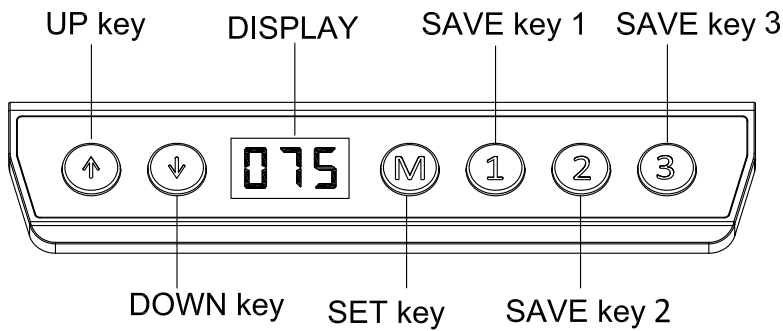

Display Windows

075 = Height

L = Locked

E * * = See Trouble Shooting

Lock and Unlock

- **Lock:** Press and hold the (M) key for 3 seconds, and when the display shows **L**, it indicates that the lifting system is locked.
- **Unlock:** Press and hold the (M) key for 3 seconds, and when the display shows a number, it indicates that the lifting system has been unlocked.

UP and DOWN Function

- When the (↑) key is pressed, the desktop runs UP until it reaches the highest point of the desktop.
- When the (↓) key is pressed, the desktop runs DOWN until it reaches the lowest point of the desktop.

Location storage/memory location query/memory location run

Location to store:

- When running to the desired height, short press (M) key, digital tube display "5-", while "-" flashing, at this time press (1)/(2)/(3) any key to store this position.

Memory location query:

- Short press (1)/(2)/(3) any key, the display flashes the corresponding memory height.

Memory location operation:

- Double-click or long press any key of (1)/(2)/(3), the desktop will automatically run to the height of the memory location. During running, any key can stop running.

Mechanical zero reset

- At the same time, press (↑) and (↓) keys for 5 seconds to display " - - - " and then release, the desktop will automatically enter the initialization mode, the table will automatically run, wait to stop, it means that the initialization is successful.

Re learn the lowest point of machinery

After descending to the lowest position, long press the (↓) key for 8 seconds. When the display screen displays " --- ", release it, and the desktop will automatically learn the lowest position. When the display screen displays normal numbers, the learning process is over. (This operation will not initialize any settings, which can solve the error code " E5F / E1B " or inconsistent table leg height)

Sitting reminder

Turn on the Sitting alert:

Hold down (M) + (2) button at the same time for 3 seconds and the screen blinks to display the time. Click (M) to switch the duration (optional : 30 minutes / 45 minutes / 60 minutes). Switch to the desired time to start the timer.

End of time:

After the time of sitting reminder, the display will blink and display [hr] for 1 minute. If there is no other operation, it will blink again 5 minutes later. If there is no other operation after repeating 3 times, it will automatically exit the sitting reminder program. If you press (M) button during the blinking period, the display will display OFF, indicating that the sedentary reminding program is closed; if other keys are clicked, the display time indicates that the timing program is restarted.

Manually turn off sitting reminders:

Hold down the (M) + (2) button at the same time ,for 3 seconds, and the display screen will display the time. At this time, press the (M) button and the display will be OFF, indicating that the sedentary reminder program is closed.

Gyroscope anti-collision protection

Anti-collision protection with built-in gyroscope on the desktop. If the desktop collides with obstacles or tilts during operation, the system will automatically stop operation and move back a short distance in the opposite direction to prevent damage to human body or objects. (Warm tip: Although the product has this function, please do not try it. Please make sure that the path of the table is free of obstacles!

Turn on or off the anti-collision:

Hold down the (M) + (3) button for 10 seconds. When OFF is displayed, it indicates turn off, when displayed ON indicates turn on.

Error code table

Display status	Explain	Process mode
E01	A The column is not connected	Press the up button or down button again. It still exists. Please check the motor line of pillar A
E02	B The column is not connected	Press the up button or down button again. It still exists. Please check the motor line of pillar B
E03	A Column motor overcurrent	Press the up button or down button again. It still exists. Please replace the motor A or reduce the load
E04	B Column motor overcurrent	Press the up button or down button again. It still exists. Please replace the motor B or reduce the load
E05	A Hall failure of column motor	Press the up button or down button again, it still exists. Please check the connection or replace motor A
E06	B Hall failure of column motor	Press the up button or down button again, it still exists. Please check the connection or replace motor B
E07	Abnormal main power supply	Unable to eliminate after power, replace the power supply
E08	A Column motor current is abnormal	Unable to eliminate after power loss need to return to the factory
E09	B Column motor current is abnormal	Unable to eliminate after power loss need to return to the factory
E10	A The power component of the column motor is broken	Unable to eliminate after power loss need to return to the factory
E11	B The power component of the column motor is broken	Unable to eliminate after power loss need to return to the factory
E12	Abnormal learning position	Relearn position
E13	Over temperature protection	Wait for the temperature to drop
E14	A Column motor is stuck	Press the up button or down button again. It still exists. Please replace the motor A or reduce the load
E15	B Column motor is stuck	Press the up button or down button again. It still exists. Please replace the motor B or reduce the load
E16	Position imbalance	Reinitializes the reset operation
r5r	Illegal power o	Reinitializes the reset operation

Trouble shooting

When a failure occurs, please refer to the following solutions, find out the presumable causes and solve the problem, if these are of no help, please refer to a professional.

PROBLEM	PROBLEM CAUSE	REMEDY
No power display	Power plug not inserted properly. There is no power in the socket. The power is not switched on.	The jack must be electrical. Press the plug. Turn on the power.

Disposal



■ If disposal of this product becomes necessary, please do this in an environmentally responsible way. Contact your local government office or authority for suitable disposal or recycling options in your local area. Do not dispose of this product, or its components, with your general domestic waste.

Contact the aftersales manager of the store where you purchased

WARNING

1. This appliance is not intended for use by persons (including children) with reduced physical, sensory or mental capabilities, or lack of experience and knowledge, unless they have been given supervision or instruction concerning use of the appliance by a person responsible for their safety.
2. Children should be supervised to ensure that they do not play with the appliance.

Purple London Ltd
Suite 3 Langford House
7A High Street
Chislehurst
BR7 5Ab
www.puruslife.co.uk